



ZANOTTI Spa
Via M.L. King, 30
46020 - Pegognaga (MN) - ITALY
Tel. +39 0376 5551
Fax +39 0376 536554
info@zanotti.com

a member of **DAIKIN** group

Datenblatt

Ausführung 2.2

Modell: **MGM320EB11XA** Kategorie: **GM**

Technische Daten

Eigenschaften	M.U.	Wert
Betriebstemperatur	°C	+10 ÷ -5
Art des Antriebs		Direkt
Spannung	Volt-Ph-Hz	380-400/3N~/50
Nennaufnahme	kW*	2,20
Nennaufnahme	Amp*	4,80
Anlaufstrom	Amp	41,0
Strom max.	Amp	11,1
Kühlmittel		R134a
	GWP	1430
Abtauzyklus		Heißes Gas
Gewicht	Kg	100

Kompressor

Typ		Hermetisch
Nennleistung	kW	2,6

Kondensator

Luftmenge	m³/h	1500
-----------	------	------

Verdampfer

Luftmenge	m³/h	1800
Wurfweite	m**	10

Kategorie PED		0
---------------	--	---



Leistungsdaten

Tc °C	Ta °C	P watt	P Kcal/h	V100 m³	V80 m³	V60 m³
	20	5081	4370	66	60	55
	25	4869	4187	63	57	52
10	30	4658	4006	60	55	50
	35	4438	3817	56	51	46
	40	4200	3612	52	47	43
	45	3934	3383	48	44	40
	20	4407	3790	56	51	46
	25	4133	3554	51	46	42
5	30	3936	3385	48	44	40
	35	3774	3246	46	42	38
	40	3603	3099	43	39	36
	45	3381	2908	40	36	33
	20	3806	3273	46	42	38
	25	3533	3038	42	38	35
0	30	3351	2882	39	35	32
	35	3210	2761	37	34	31
	40	3064	2635	35	32	29
	45	2864	2463	32	29	27
	20	3266	2809	38	35	32
	25	2956	2542	33	30	27
-5	30	2777	2388	30	27	25
	35	2667	2294	29	26	24
	40	2562	2203	27	25	22
	45	2396	2061	25	23	21

* Bei Betrieb: 0 ÷ +30°C

** Standartwert, der Luftwurf ist von zahlreichen Faktoren abhängig: Kühlzellenhöhe, Lagerart, Verdampfer Montageort, usw.

Tc: Raumtemperatur. - Ta: Außere Temperatur.

P: Abkühlende Kapazität - V: vorgeschlagen Kühlraum Volumen

L'immagine è datata e potrebbe presentare alcune differenze rispetto all'unità attuale. La aggiorneremo il prima possibile.
 The picture is old and it could have some differences from the current unit. We will update it as soon as possible.

Dimensioni - Dimensions - Dimensions
 Abmessungen - Dimensiones

GM3

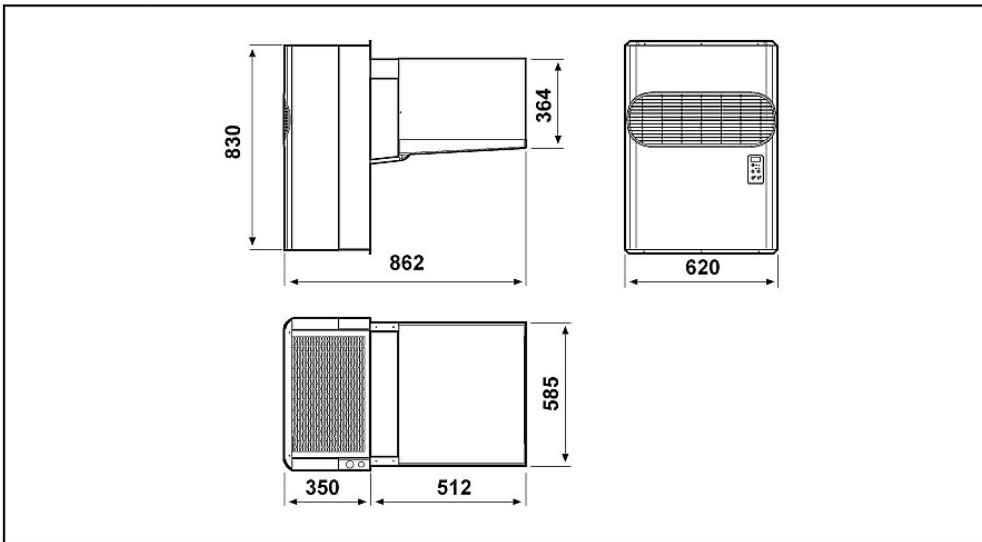

Schema di montaggio - Mounting scheme - Schema de montage
 Montageschema - Esquema de montaje

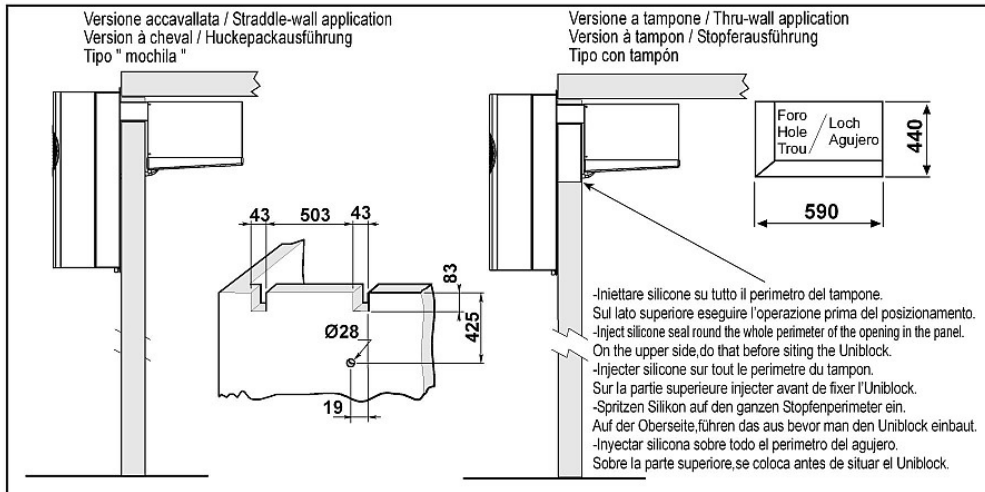

- * Raccomandazioni in sede di installazione e per il controllo fornite sul manuale di installazione
- * To be advised at time of order for factory installation and operating instructions
- * Recommendations au moments d'installations et pour le contrôle fournis sur le manuel d'installation
- * Empfehlungen für die Installationsphase und zur Kontrolle, die im Handbuch zur Installation enthalten sind
- * Por cuanto respecta a recomendaciones de instalaciòn y control ver manual de instalaciòn

Massa e misure imballi - Packing mass and dimensions - Masse et dimensions emballages
 Verpackungsmasse und-abmessungen - Masa y medidas del embalaje

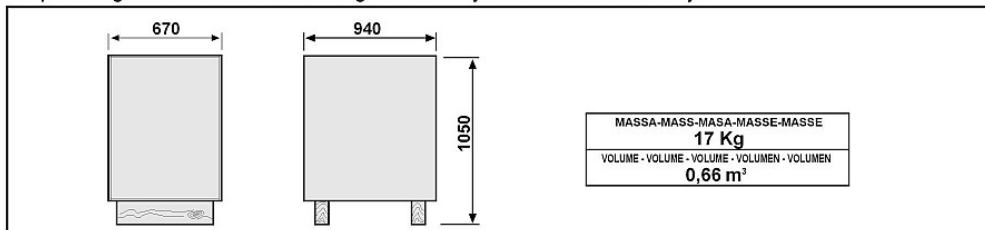

ZANOTTI S.p.A.